

ULTIMA[®] ELECTRONIC WIRING SYSTEM

#18-530 INSTRUCTIONS

1. Find a mounting location for control box. The box is designed to be mounted to the top frame rail between split tanks, but can be mounted in a wide variety of places. If possible the box should be fastened using small screws or rivets but can be wire tied in place. Make sure the location is away from moving parts and heat sources.

2. Pre-fit harness to bike. Attach rear harness to control box. Each wire is color coded and labeled. Route individual wires to their destinations and do not cut to length. Keep wires in a bunch until they need to branch off. Use electrical tape to hold main wire bunch wherever individual or multiple wires branch off. Keep wires away from sharp edges or pinch points and leave extra wire for suspension movement. Repeat this for front and right/left harnesses. All wires not being used should be cut off at connector or secured to prevent shorts. When all wires are routed, cut excess length from ends leaving a couple extra inches for final fitment.

3 Remove pre-fitted harness from bike to install heat shrink tubing. Start at main connector and cut tubing approximately 1 inch past first branch. This will allow the next piece of tubing to slide into the first. Repeat this along entire harness. After encasing harness with heat shrink, use a heat gun to shrink tubing starting at main connectors. Be careful to not burn through the tubing with too much heat. Refit the harness to the bike, attaching to frame where necessary. Cut the ends of harness to length and strip the ends. Attach the terminals to the wire ends and use heat gun to shrink ends. Attach terminals to their destinations.

4. The diagnostic LED's are used to locate shorts or overloads. Pinched or bare wires, faulty components or too much current draw usually causes these. If an LED is on, turn off the bike, locate and correct the problem, then turn the bike back on. The bike must be turned off to reset the protection circuit.

If no LED's are lit, but turn signals and dash lights do not work properly, make sure the control box main ground has a good connection to the chassis ground.

5. The control box operates the turn signals as listed:

First command – flash 10 times then cancel

Second command on same side – cancel

Second command opposite side – cancel current sequence, flash 10 times then cancel

Both sides at same time – hazard, all signals flash

Brake switch – flash rear signals three times then stay on for 30 seconds

Note: To use full diagnostics on 96 & later handlebar controls you must separate the Orange/White power wires that are spliced together inside both left and right handlebar harness. Once separated, extend the wires using a butt connector or solder and heat shrink and attach individual wires to 9 pin connector as indicated on wiring diagram.

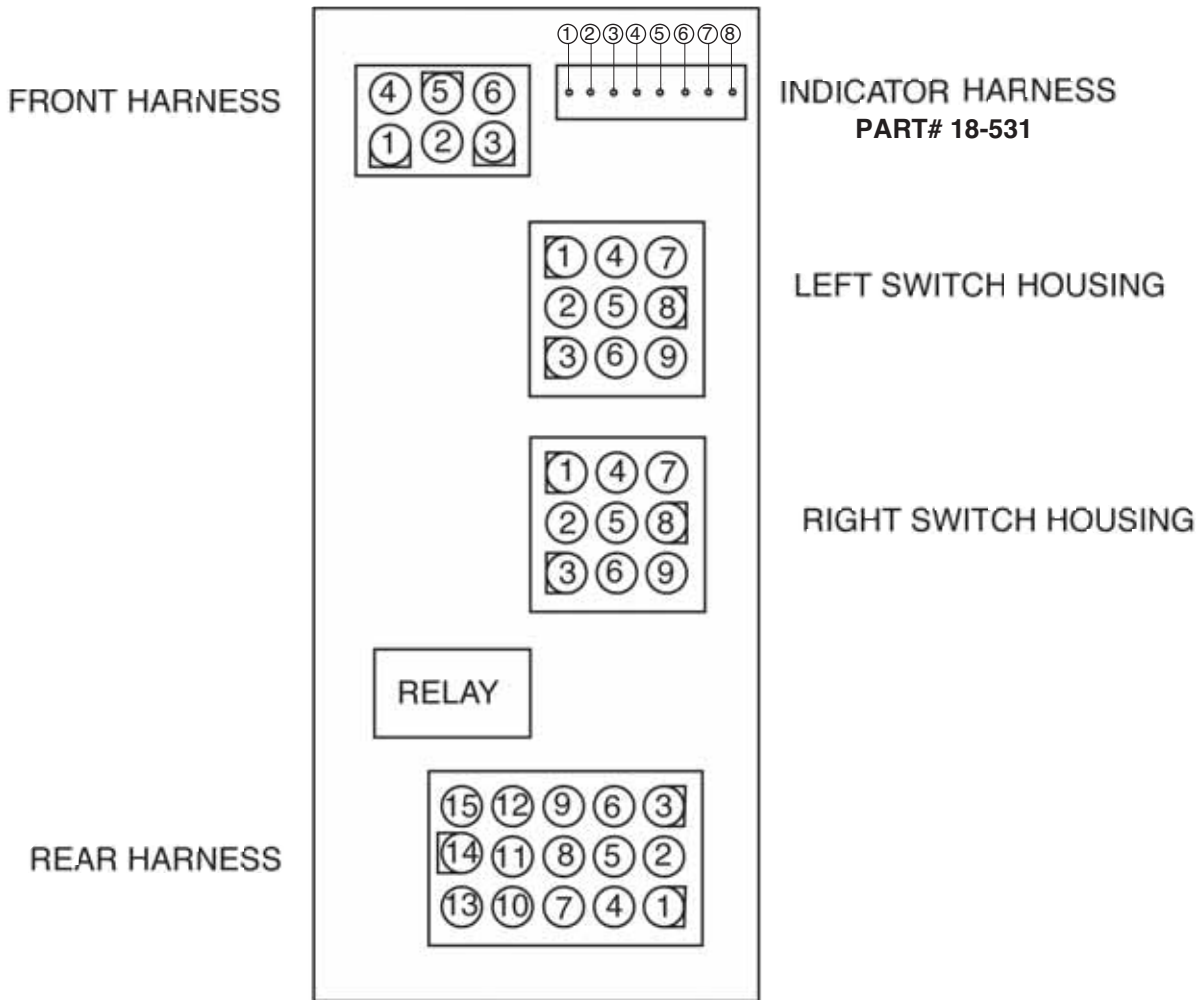

INDICATOR HARNESS (IF USED) PART#18-531 - LED ONLY

	<u>FUNCTION</u>	<u>COLOR</u>
1	Right Signal	Brown
2	High Beam	Red
3	+12V (Oil) (Pin 11 Rear Harness)	Orange
4	+12V (Neutral) (Pin 10 Rear Harness)	Yellow
5	Neutral	Green
6	Left Signal	Black
7	Oil Pressure	Blue
8	Ground (Right signal, left signal, High Beam)	White

FRONT HARNESS

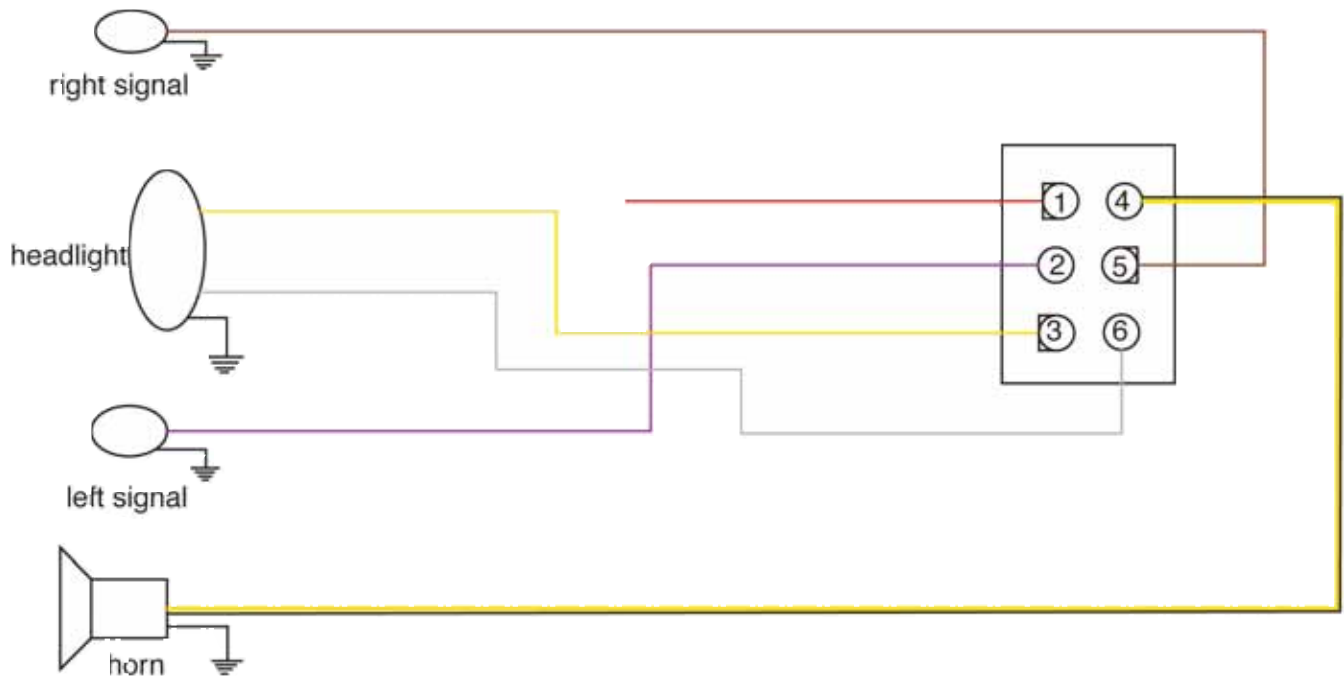

PIN	FUNCTION	COLOR
1	auxiliary power (3a)	red
2	left front turn signal	violet
3	headlight low beam	yellow
4	horn	yellow w/ black stripe
5	right front turn signal	brown
6	headlight high beam	white

REAR HARNESS

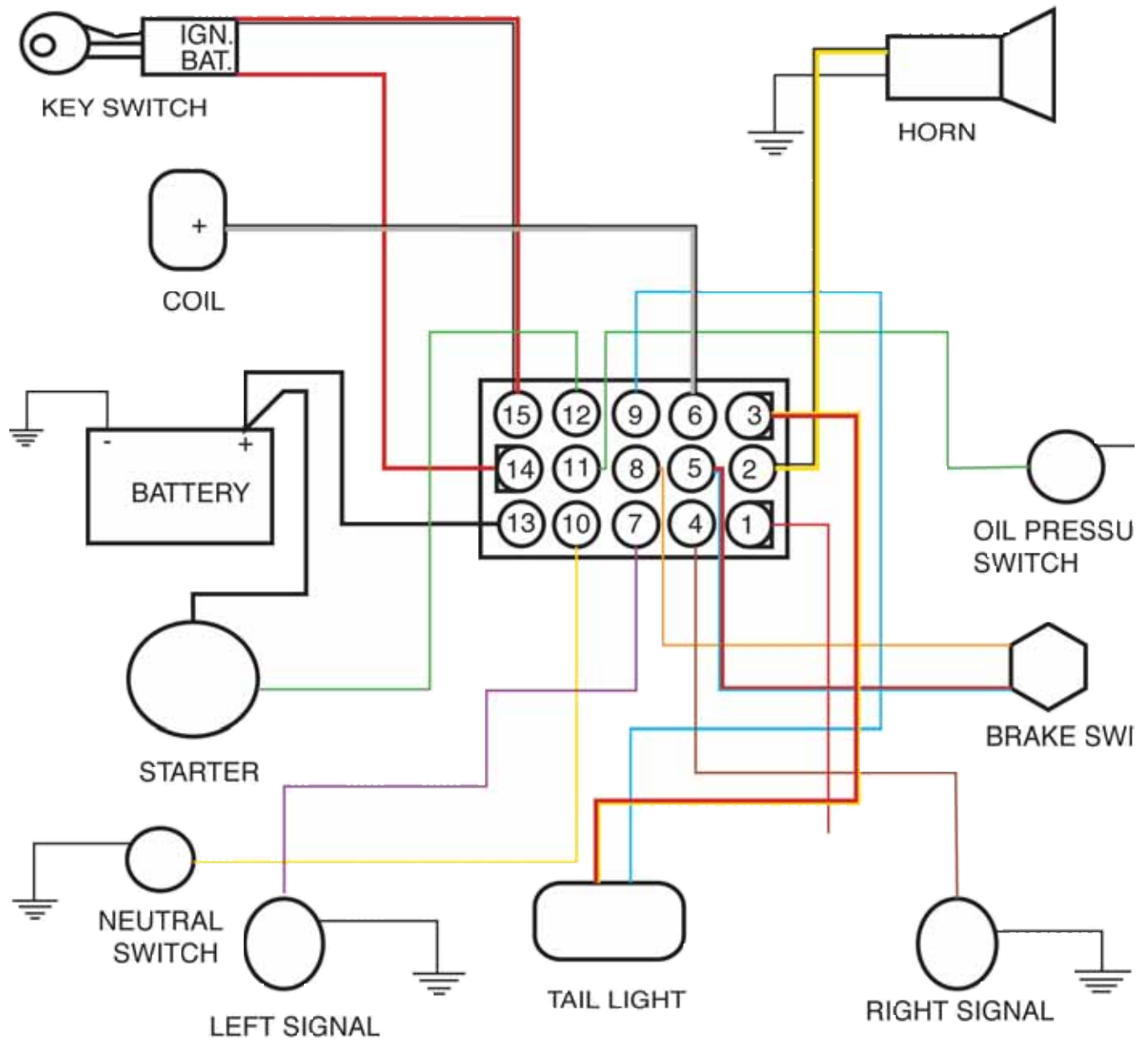

PIN	FUNCTION	COLOR
1	auxiliary power	red
2	horn (alternative)	yellow w/black stripe
3	brake light	red w/ yellow stripe
4	right rear turn signal	brown
5	brake switch	red w/blue stripe
6	coil	white w/black stripe
7	left rear turn signal	violet
8	brake switch	orange
9	tail light	blue
10	neutral switch	yellow
11	oil pressure switch	green

HANDELBAR HARNESS 82-95

LEFT SWITCH HOUSING

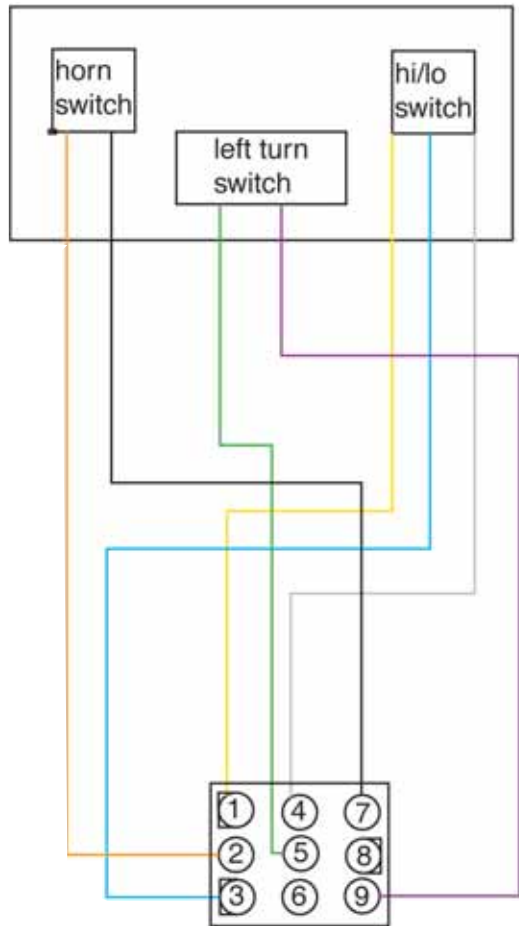

RIGHT SWITCH HOUSING

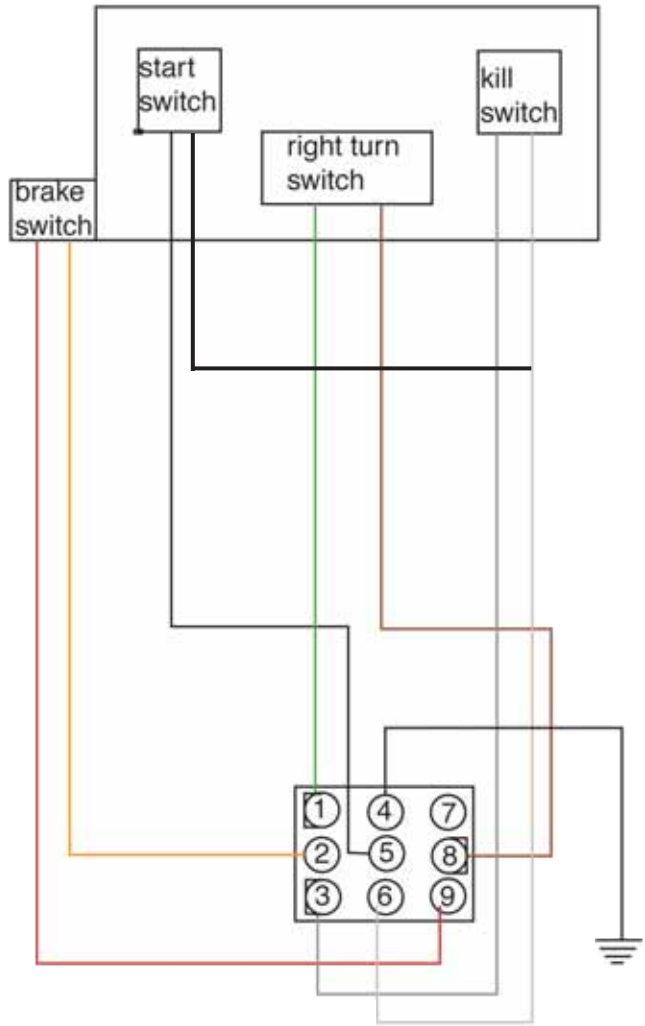

LEFT SWITCH HOUSING CONNECTOR

PIN	FUNCTION	COLOR
1	low beam	yellow
2	horn switch power	orange
3	hi/lo switch power	blue
4	high beam	white
5	left turn power	green
6	N/A	N/A
7	horn	black
8	N/A	N/A
9	left turn switch	violet

RIGHT SWITCH HOUSING CONNECTOR

PIN	FUNCTION	COLOR
1	right turn power	green
2	brake switch power	orange
3	kill switch power	grey
4	ground	black
5	start switch	black
6	kill switch	white
7	N/A	N/A
8	right turn switch	brown
9	brake light switch	red

HANDELBAR HARNESS 96L

LEFT SWITCH HOUSING

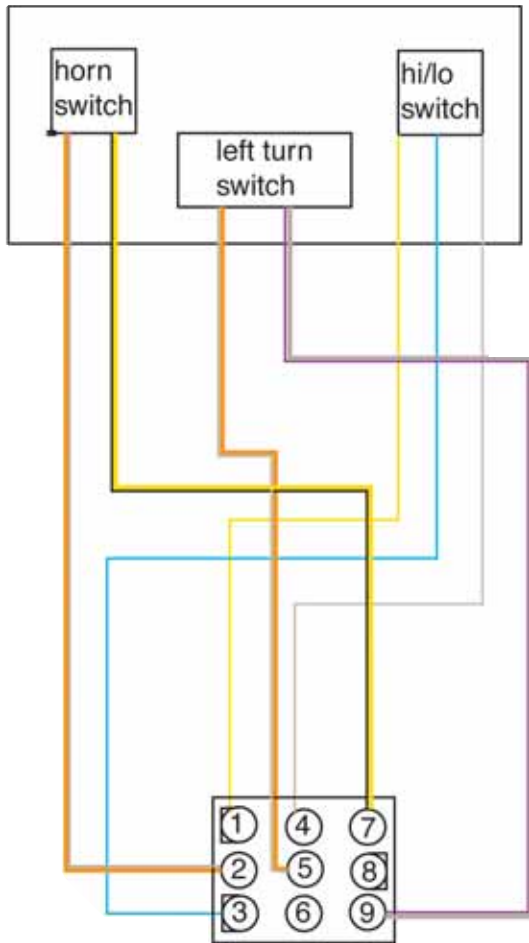

RIGHT SWITCH HOUSING

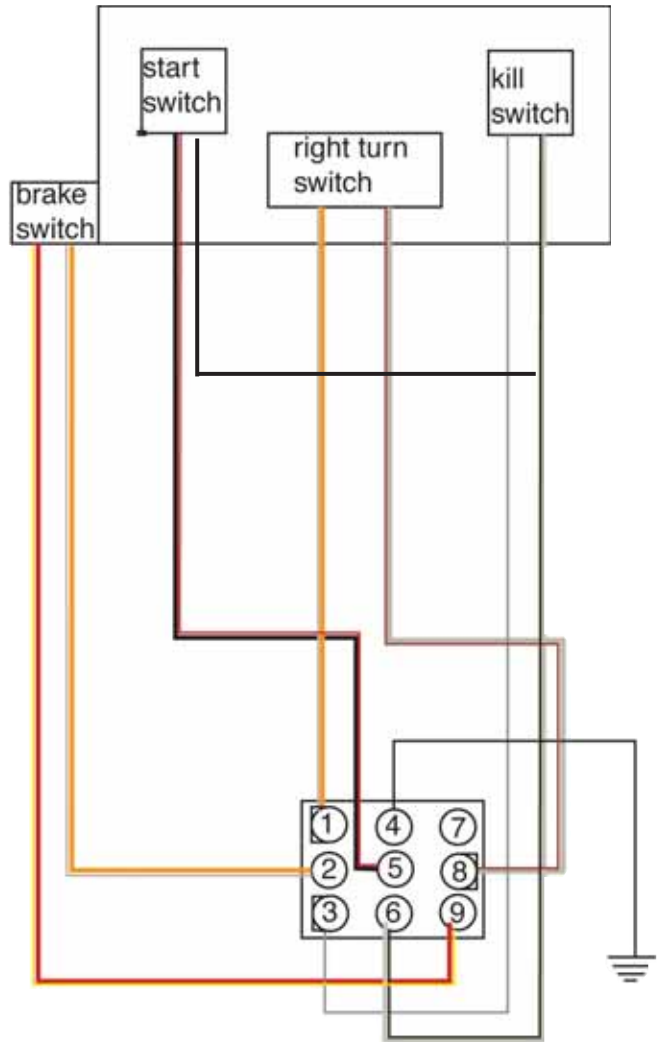

LEFT SWITCH HOUSING CONNECTOR

PIN	FUNCTION	COLOR
1	low beam	yellow
2	horn switch power	orange w/white stripe
3	hi/lo switch power	blue
4	high beam	white
5	left turn power	orange w/white stripe
6	N/A	N/A
7	horn	yellow w/ black stripe
8	N/A	N/A
9	left turn switch	white w/violet stripe

RIGHT SWITCH HOUSING CONNECTOR

PIN	FUNCTION	COLOR
1	right turn power	orange w/ white stripe
2	brake switch power	orange w/ white stripe
3	kill switch power	grey
4	ground	black
5	start switch	black w/red stripe
6	kill switch	white w/black stripe
7	N/A	N/A
8	right turn switch	white w/brown stripe
9	brake light switch	red w/yellow stripe